

AT2331 Emergency Alarm Dosimeter

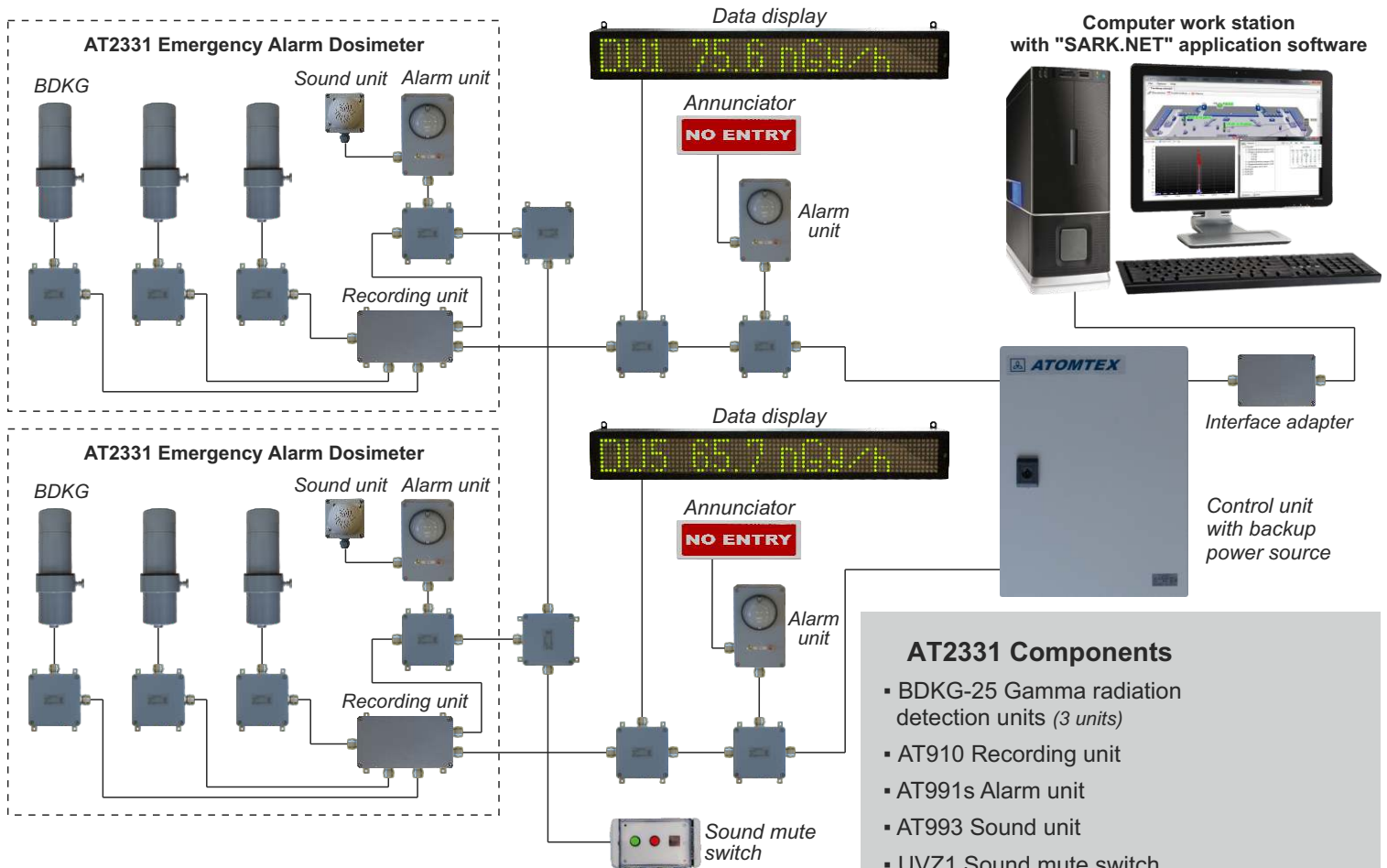

Sample functional chart of **Alarm systems for occurrence of self-sustaining chain reaction**

AT2331 Emergency Alarm Dosimeter is designed for detection of self-sustaining chain reaction and generation of sound and light alarm signals to evacuate personnel from hazardous area.

Operating principle

Alarm dosimeter is a fixed design package consisting of gamma radiation detection units, processing and alarm units for on-site installation.

Alarm dosimeter operation principle is based on gamma dose rate measurement by BDKG unit, results matching with pre-set threshold levels, "2 from 3"/"OR" logic processing of BDKG unit signals about exceeded alarm threshold levels to generate alarm signal to indicate self-sustaining chain reaction condition.

Instrument can accept data about two dose rate measurement threshold levels and store it for further use when alarm dosimeter is powered on.

AT2331 Alarm dosimeter can be connected to AT2327 Alarm dosimeter or PC using "SARK.NET" software to create an emergency alarm system.

Up to 3 alarm dosimeters can be connected to AT2327 and up to 32 alarm dosimeters – to PC.

When AT2331 Alarm dosimeter is a part of emergency alarm system, operating one alarm dosimeter triggers all alarm dosimeters of the system. The sound mute switch can be used to deactivate audible alarm after personnel evacuation.

If malfunction of one unit from emergency alarm dosimeter or communication line occurs, the rest of the units will continue operating in stand-alone mode preserving all detection, alarm, measurement and data storage functions.

AT2331 Components

- BDKG-25 Gamma radiation detection units (3 units)
- AT910 Recording unit
- AT991s Alarm unit
- AT993 Sound unit
- UVZ1 Sound mute switch
- ASTO 12/1 Annunciator
- Interface adapter (RS485/USB)
- Set of switches and terminal-block boxes
- Mounting brackets
- Calibration accessories
- User's manual

Application

- Safety assurance for staff of companies utilizing, processing and storing fission materials

Features

- Detection of self-sustaining chain reaction in full range of its characteristics
- Smart probes
- Long operation life
- High reliability
- Self-monitoring of component parts
- Backup power supply unit
- Writing and storing measurement results in non-volatile memory of alarm dosimeter
- Automatic monitoring of battery level



ATOMTEX[®]

INSTRUMENTS AND TECHNOLOGIES FOR NUCLEAR MEASUREMENTS AND RADIATION MONITORING

AT2331 Emergency Alarm Dosimeter

Specifications

Minimum duration of the registered self-sustaining chain reaction	1 ms
Measurement range of x-ray and gamma radiation absorbed dose rate	0.1 μ Gy/h – 1 Gy/h
Measurement range of x-ray and gamma radiation absorbed dose	0.05 μ Gy – 10 Gy
Limits of tolerable intrinsic relative error of measurement - For dose rate measurement - For dose measurement	$\pm 30\%$ $\pm 35\%$
Energy dependence relative to 662 keV (^{137}Cs)	$\pm 35\%$ (in 60 keV – 3 MeV energy range)
Measurement time of x-ray and gamma radiation dose rate (1 μ Gy/h) with maximum statistical error 20%	≤ 120 s
Selectable dose rate operation threshold range	1 μ Gy/h – 1 Gy/h
Time interval from the moment of detection unit actuation to the moment when the rated alarm sound level is reached	≤ 0.5 s
Alarm sound level at 1-meter distance	100 dB
Maximum distance of communication line between alarm dosimeter components to maintain operation	≤ 1000 m
Initialisation time	≤ 5 min
Power supply	110-230 VAC, 50-60 Hz or 24 VDC battery in case of mains power failure
Continuous run time	≥ 24 h with AC mains power supply; ≥ 6 h in case of self-contained operation from fully charged battery
Burn-up life	≥ 100 Gy
Mean operating life	≥ 20 years
Mean time to failure	≥ 15.000 h
Protection rating - For BDKG-25, terminal-block boxes and switches - For other components	IP57 IP65
Operation temperature range - For BDKG-25, AT910, switches and terminal-block boxes - For other components	-40°C ... +50°C +5°C ... +40°C
Relative air humidity - For detection units, switches and terminal-block boxes (With air temperature $\leq 35^\circ\text{C}$ without moisture condensation) - For other components (With air temperature $\leq 30^\circ\text{C}$ without moisture condensation)	$\leq 95\%$ $\leq 75\%$
Dimensions and weight of components: BDKG-25 Detection unit AT910 Recording unit AT991c Alarm unit AT993 Sound unit Terminal-block box Switch AT980 Control unit (Without batteries) Data display [From AT2327 delivery package]	$\varnothing 61 \times 210$ mm; 0.6 kg 270x168x85 mm; 1.9 kg 141x185x112 mm; 1.4 kg 125x133x125 mm; 0.9 kg 145x150x85 mm; 0.8 kg 145x150x85 mm; 0.8 kg 400x300x150 mm; 7.8 kg 643x97x67 mm; 4.0 kg

AT2331 Emergency alarm dosimeter as part of emergency alarm system complies with requirements of "Design and operation industry regulations on alarm systems for occurrence of self-supporting chain reaction and on arrangement of consequence restriction measures" ПБЯ-06-10-99 and takes into account International Electrotechnical Commission IEC-860 (1987) recommendations and regulatory requirements of US Standard ANSI/ANS-8.3 Criticality Accident Resources and Information Alarm System (1986).

AT2331 Emergency alarm dosimeter complies with fire safety code GOST 12.1.004-91, electrical safety requirements GOST 12.2.091-2012 and electromagnetic compatibility requirements: STB IEC 61000-4-2-2011, STB IEC 61000-4-3-2009, STB IEC 61000-4-4-2006, STB IEC 61000-4-5-2006, STB IEC 61000-4-6-2011, STB IEC 61000-4-8-2011, STB IEC 61000-4-11-2006.

Design and specifications are subject to change without notice